



XING FA



COMPRESORES HERMETICOS

BAJA TEMPERATURA R-404A

Aceite Polyolester

Potencia (Hp)	MODELO	Desplazamiento (cm ³ /rev.)	Carga Aceite cm ³	Enfriamiento	Rendimiento Frigorífico (Kcal/h)							Volts / Nº f / Hz	Ø Succión	Ø Descarga	Peso Bruto Kg	H Altura (mm)
					Temperatura Evaporación											
					-40°C	-35°C	-30°C	-23°C	-20°C	-10°C	0°C					
2	XDCOQL52M	52,0	1500	V	-	598	1075	2090	2110	3450	3975	220/1/50	7/8"	1/2"	33	355
2,5	XDCOQL74T	74,2	1500	V	-	1055	1626	2580	3110	5220	6175	380/3/50	7/8"	1/2"	33	355
4	XDCOQL112T	112,5	2000	V	-	1430	2278	3670	4350	7615	7995	380/3/50	7/8"	5/8"	46	398
5	XDCOQL134T	134,8	2000	V	-	2003	2985	4663	5635	9320	9786	380/3/50	7/8"	5/8"	46	398

Temperatura Condensación 54°C

V = Ventilación Forzada

DIMENSIONES GENERALES

Compresores (2 - 2.5 Hp)

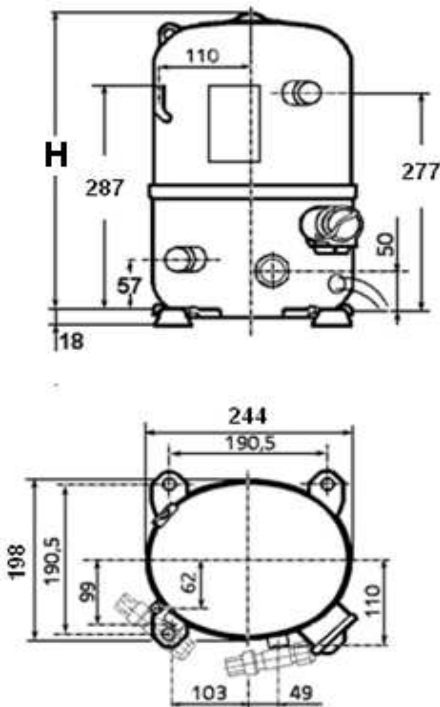

Compresores (4 - 5 Hp)

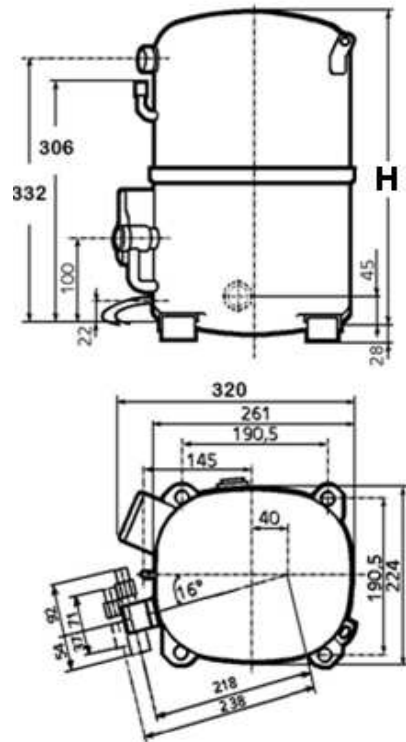

La empresa se reserva el derecho de realizar modificaciones en los equipos sin previo aviso